

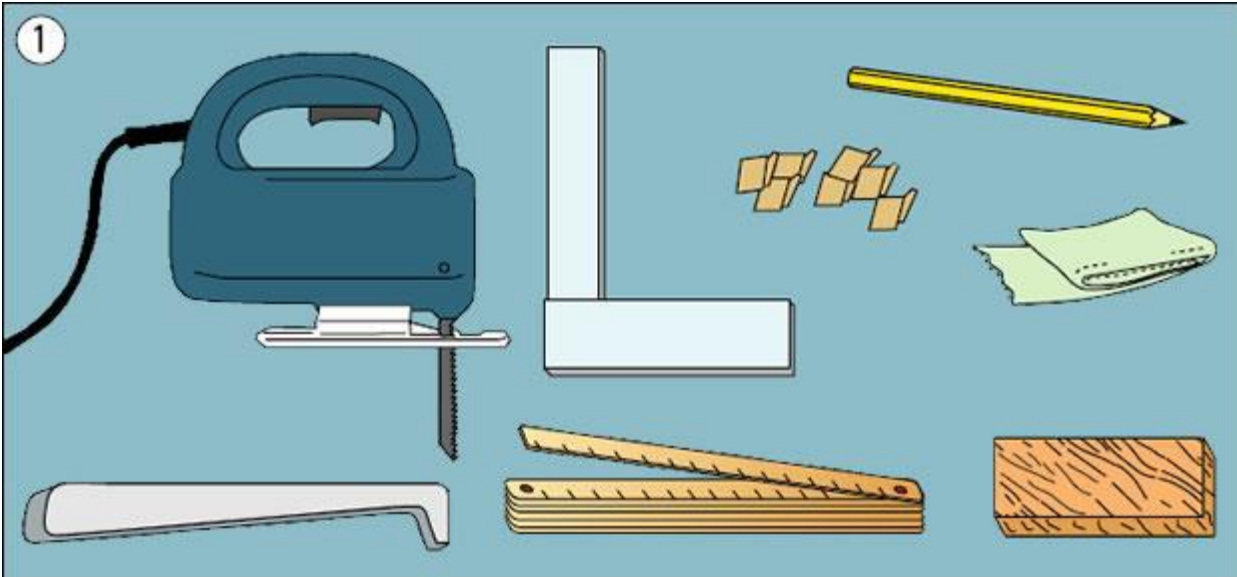

Installation Method for Robina Laminate Flooring

HERE'S WHAT YOU'LL NEED:



STEP 1 - General tools needed are pencil, measuring tape, square ruler, whip saw or a fretsaw and a number of wedges or spacers.

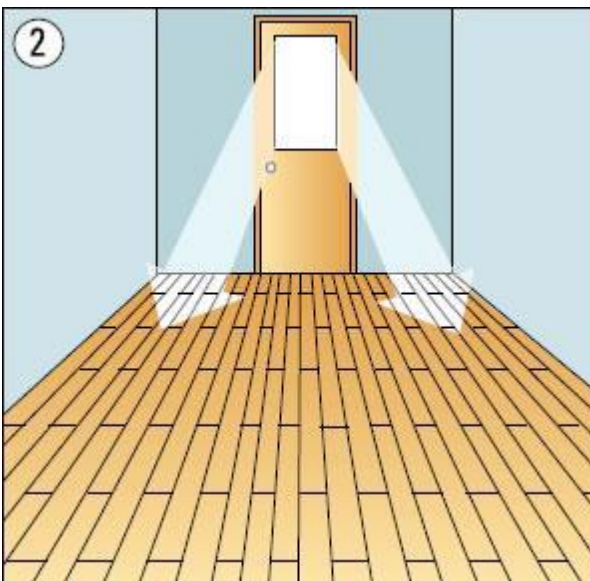

STEP 2 - Aesthetically, laminate flooring should be laid parallel to the direction of the incoming light. This helps to diminish the appearance of long seam between panels. Lay in the longitudinal direction in a long and narrow room.

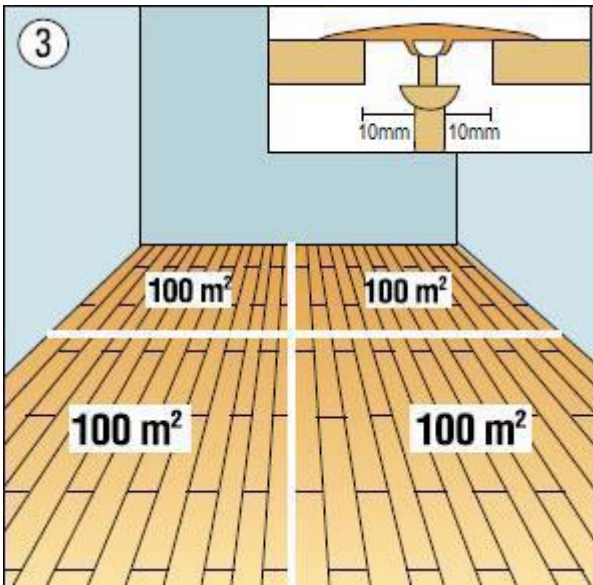

STEP 3 - If the install areas are more than 100m², it is recommended to use suitable profiles to separate the floors. This is also applicable if laying the flooring over several rooms, even though the room sizes may be less.

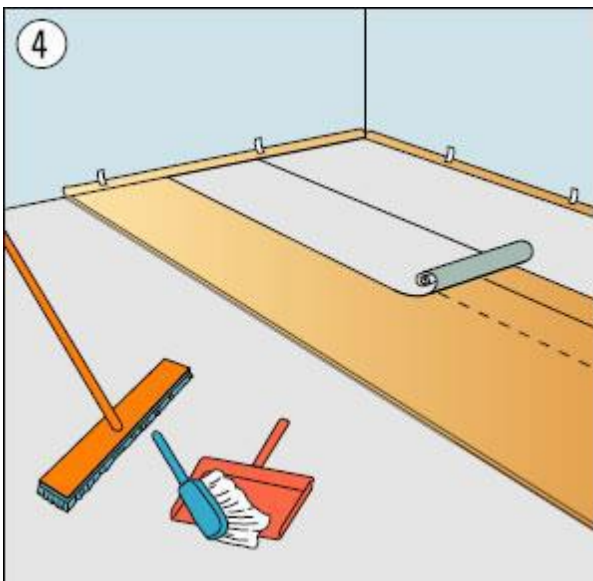

STEP 4 - When the sub floor had been prepared accordingly, lay the P.E. sheets and the P.E. foams underlay for the next 5~10 rows of panes that you will install.

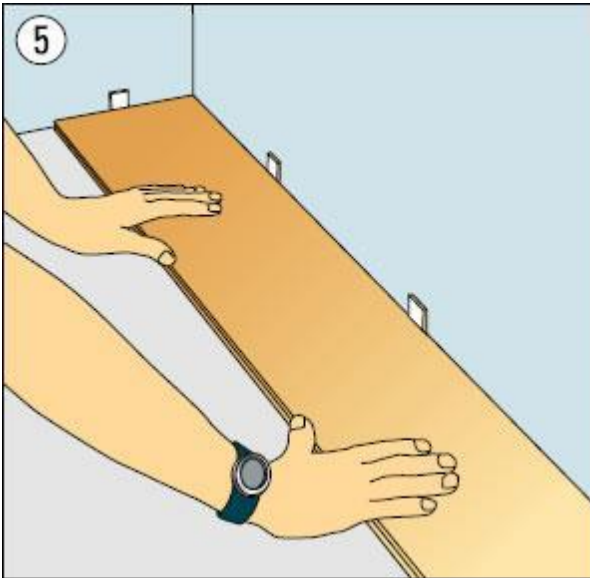

STEP 5 - Before you start to install the panel, to avoid the last panels being narrower than 2" (50mm), measure the room width and divide with the panel width. If necessary, saw off the first row in order to have the last row more than 2" wide. Now start from the left corner of the room and lay the first panel with the tongue (must be cut off) side towards the walls. Ensure at least 3/8" to 5/8" (10 ~ 15 mm) expansion gap around the perimeter of the room as well as against any fixed object. Use spacers or wedges to safeguard the first row.

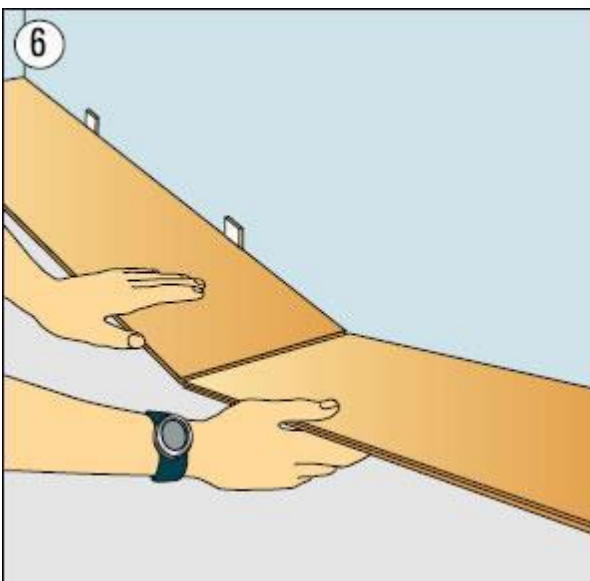

STEP 6 Position the second panel with its tongue side at an angle against to the groove of the first panel already in place. Slightly push in and bring down the second panel to connect these two panels. Repeat these steps to complete the first row.

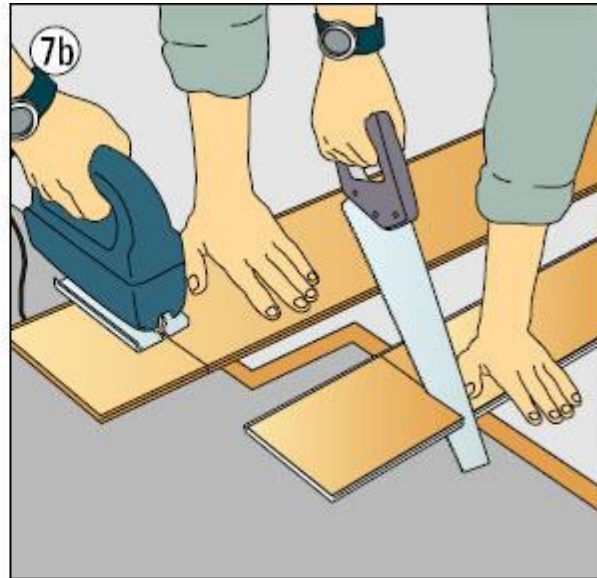
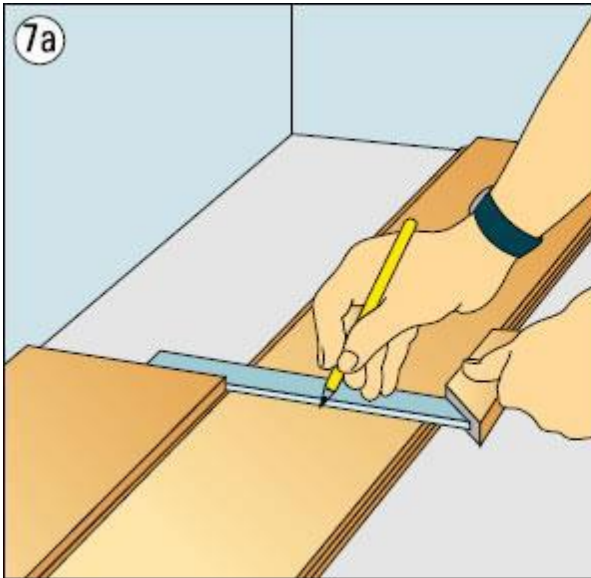

STEP 7 Measure and cut-off the last panels of the first row. The cut-off materials from the first row can be used to begin the second row, but it must be more than 12" (300mm) in length.

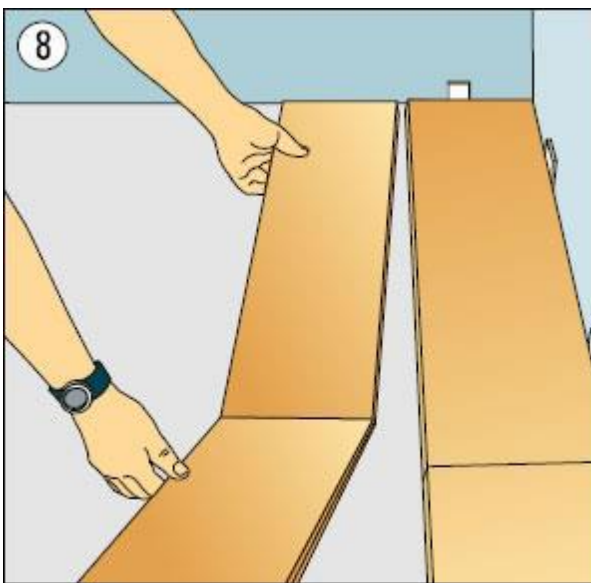

STEP 8 Apply the same methods as the first row to join the panels of the second row.

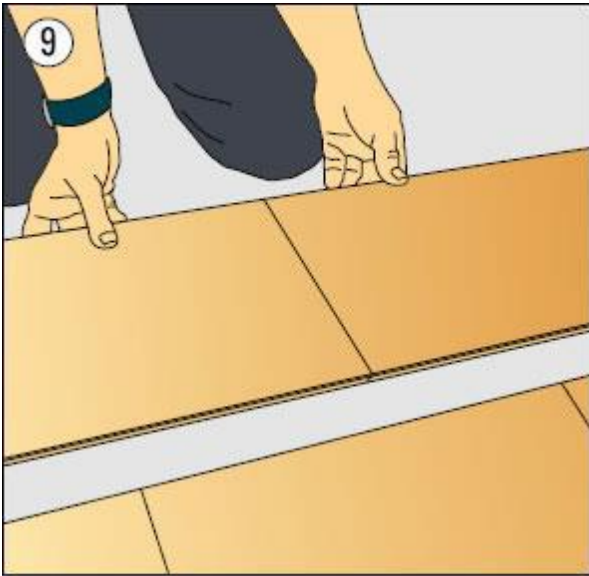

STEP 9 Tilt the panels together and position the tongues into the grooves of the previous row at an angle.

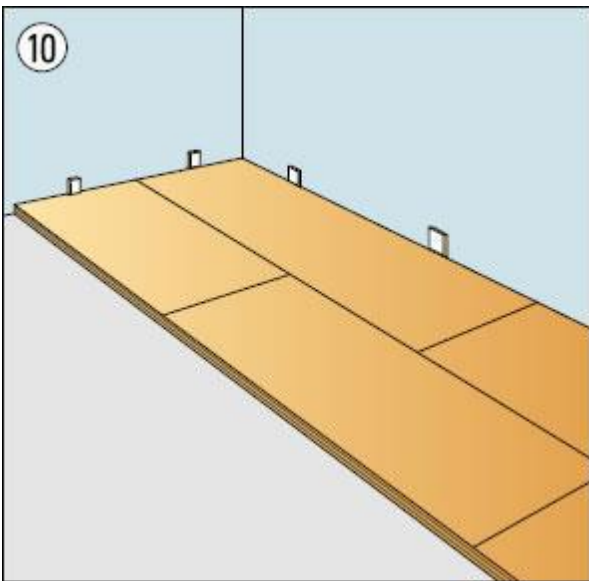

STEP 10 Slightly push in and bring the panels until fully flat down. Panels in adjoining rows must be off-set at least 12" minimum. Do not make the first panel of each the same length.



STEP 11 As of the 4th row onwards, apply the same method as 2nd and 3rd row but position yourself on the flooring which had been installed.

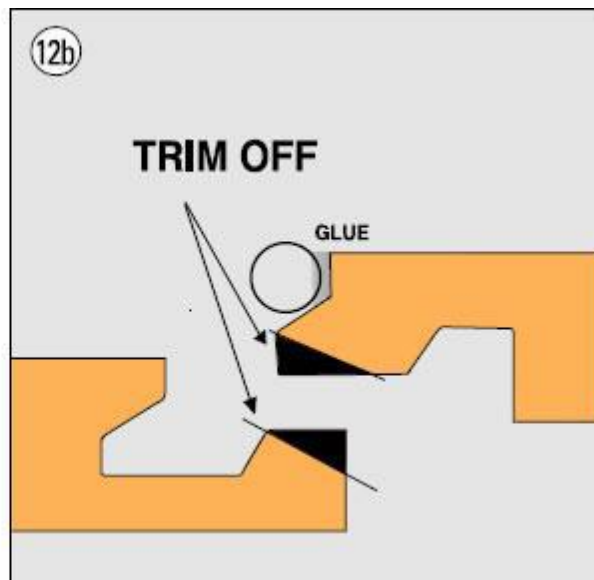
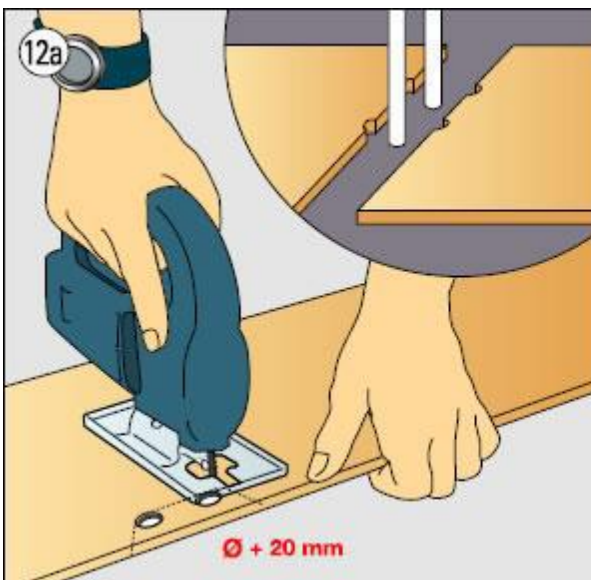

STEP 12 Cut holes on floors panels around obstacles like pipe, pillar and post. Remember to leave enough expansion gaps around all these obstacles. Sometimes, door frames, kick bases and counter bases need to be undercut to hide the panel's edge. Always allow proper expansion gaps behind the undercut. When you are facing difficulties at areas where lifting panels up and down are impossible to connect new panels to the panels previously laid (e.g. beneath a door frame), use a chisel to lower the elevated portion of the groove. Be careful not to trim too much or else it will weaken the joint. Apply sufficient glue onto the modified groove, until you see it squeezed out between joint when you slide the panels together. Wipe off the glue residue with a damp cloth and use strong adhesion tape to hold the joint tightly for minimum 12 hours.

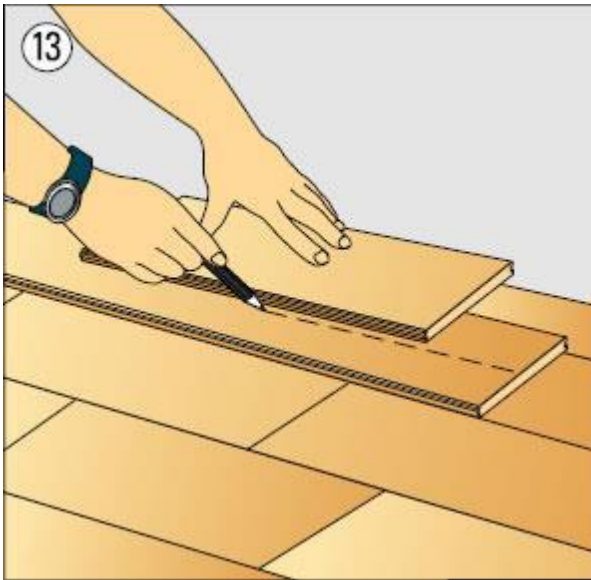

STEP 13 For the final row, if the wall is not straight, adapt the panel to the course of the wall by using a small piece (as a rule), place it on top of the cull panel. Use a pencil to mark on the full panel and cut according to the marking line, with the consideration of sufficient expansion gap.

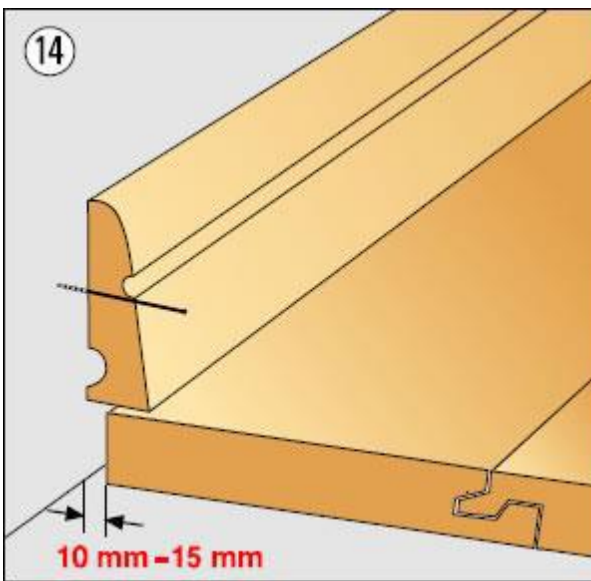

STEP 14 Remove all spacers, install the skirting and profiles. Do not fasten them on the laminate flooring. A durable elastic substance can be used to seal gaps.